



fibertwist
innovative fiber & network demarcation

A matching solution for each deployment scenario

The FTTH market is rapidly evolving. Technology now relevant, might be outdated tomorrow, and consumer needs and wishes play a central role. Providing fiber connectivity anywhere in the home, scalable secure and compact, is one of today's major challenges. Genexis' FiberTwist solves exactly that challenge.

FiberTwist is a unique FTTH connectivity solution that redefines size, ease-of-installation and flexibility for the distribution of fiber bandwidth through the home. With FiberTwist, you only need one product to cover each and every deployment scenario in your network.

✓ Point-to-Point & GPON

✓ Single & multi fiber

✓ Single & multi dwelling

✓ Extend connectivity to any place in the home



Ultra-compact fiber termination

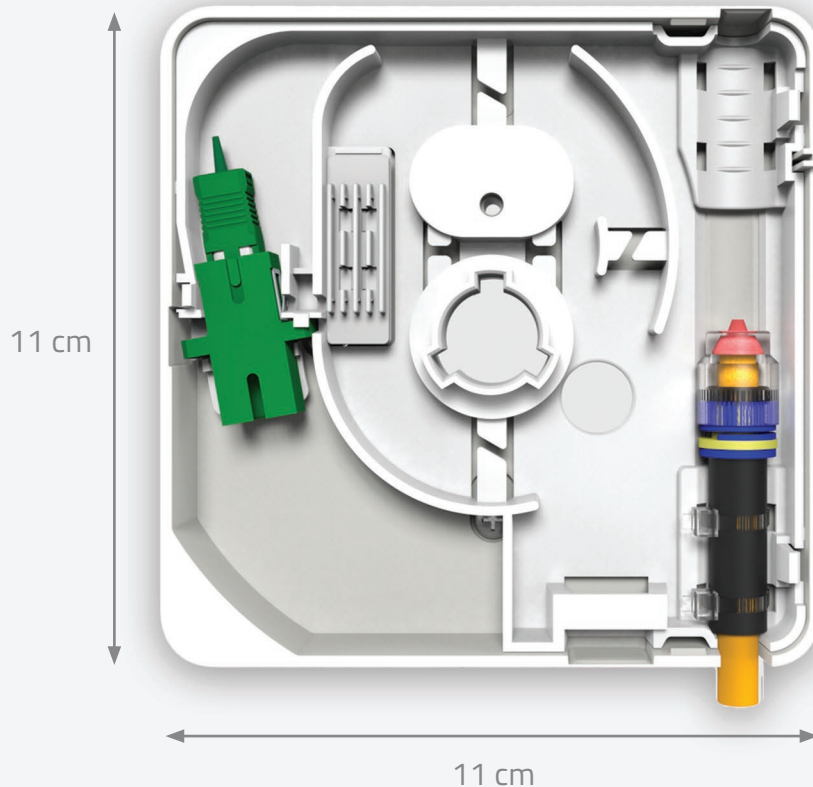

Would you like to use the FiberTwist FTU as a passive fiber demarcation node? Then finish the product with the FiberTwist patch cover, enabling fully protected and end-user friendly fiber patching.



Every in-home fiber connection needs a solid base to build on. A base that provides secure fiber storage, mature fiber termination and patching capabilities, combined with the option to directly connect active equipment.

The FiberTwist packages all those needs in a super compact design of only 11 x 11 cm. Its patented Twist interface enables easy installation of active equipment as well its fiber patch module. Furthermore, the FTU's fiber management system cleverly integrates all technical features one would expect of a professional FTU.

Features:

- Compact design requiring limited installation space
- Single-fiber design; multi-fiber optional
- Simple and secure fiber patching of up to 2 fibers
- Rock-solid fiber management
- Ready for bottom, top or back fiber entry
- Ready for the addition of a gasblocker
- Integrated fiber pull relief and protection

Revolutionary do-it-yourself installation



True 'do-it-yourself' installation has been claimed many times before in the FTTH industry. This is of course not without a reason: decreasing operational expenses by saving on a costly installer is of great interest to network operators.

FiberTwist introduces an installation mechanism never seen before in FTTH products. With one clever twist any end-user can install an active module on the FTU: no hassle, no hiccups and a 100% accurate installation.

FiberTwist interface benefits:

- Reduced OPEX, no expensive installer needed
- Increased First-Time-Right installation
- 100% accurate fiber connection
- Reduced required installation space
- Greatly lowers the technical barrier surrounding FTTH for end-users

Powerful Layer-2 network demarcation

- ✓ Point-to-Point and GPON
- ✓ TR-069 managed network demarcation
- ✓ Up to 4 Gigabit LAN ports
- ✓ Integrated CATV
- ✓ Compact, clean design (11 x 11 x 4,6 cm)
- ✓ Patented FiberTwist interface
- ✓ End-user installation, reducing OPEX
- ✓ LED dimming

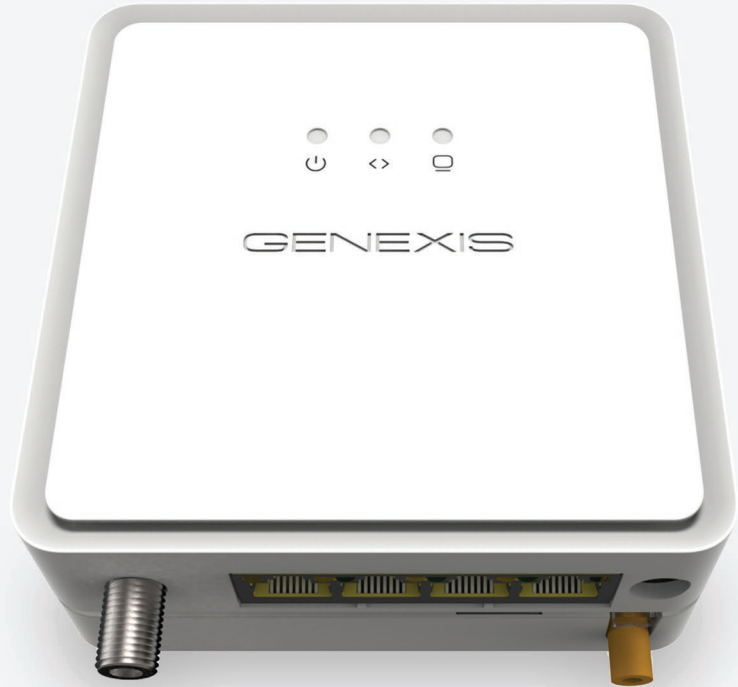

Would you like to receive more information about FiberTwist?

Please visit our website at www.genexis.eu





info@genexis.eu | 31 (0) 40 747 0247
Lodewijkstraat 1a | 5652AC Eindhoven | The Netherlands

www.genexis.eu